

ASSEMBLY INSTRUCTIONS

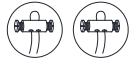

1. Wrap the safety cable into the slot hole on the mounting plate (B).
2. Wrap the safety cable around the cable lock nut.
3. Insert screws into both holes on cable lock nut, secure screws with screwdriver.

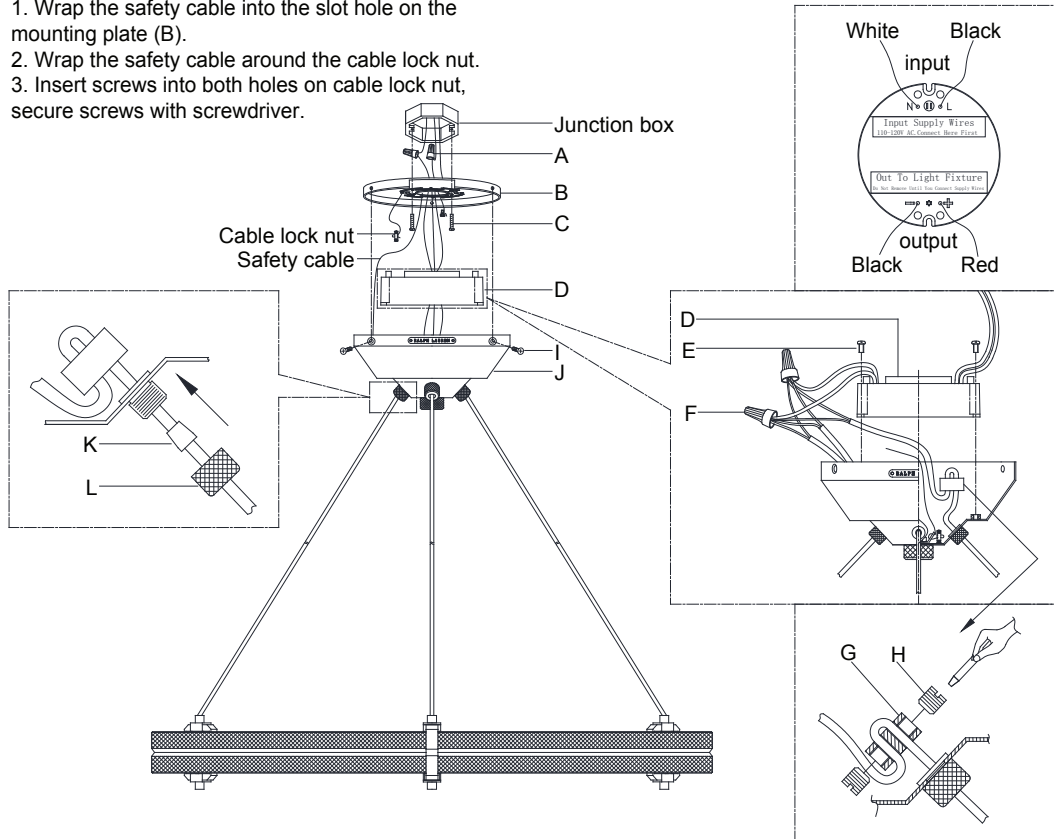

Paxton 24" Ring Chandelier

Item # RL 5670

NOTICE:

This light fixture should be installed in accordance with all applicable, local installation codes, and by a person familiar with the construction and operation of it, as well as the hazards involved. Inspect item and contents carefully. If any damage or defect is found, do not install. Retain all packaging material until installation is complete and approved.

1. Carefully remove all parts from the box.
2. Remove the mounting plate (B) from the canopy (J) by unscrewing the canopy screws (I).
3. Install the mounting plate (B) to the junction box and secure with the mounting screws (C).
4. Wrap the junction box ground wire to the green ground screw on the mounting plate (B) and secure.
IT IS IMPERATIVE THAT THIS FIXTURE BE GROUNDED.
5. Gently set the fixture on a flat, non-abrasive surface to adjust fixture hanging wires.
6. To adjust each hanging wire loosen the screws (H) on either side of the cable lock nut (G) and adjust to desired length. Once complete re-secure screws (H) and repeat steps with the remaining wires.
7. After fixture height is achieved shorten the wires by using a pair of cutters (not included), leaving 8" of wire length to connect to driver (D). PLEASE NOTE: Final leveling in later step will only allow for small adjustments. Make sure fixture height and fixture level are accurate before cutting wires.
8. Remove outer housing of wire by making a neat cut all the way around, about 1" from the end. Make sure not to cut too deep or electrical wires could be damaged underneath. Once cut is made, remove and discard the 1" piece of housing off the end, exposing the electrical wires.
9. Strip the insulation on the electrical wires back about 5/8".
10. Install the driver (D) to the canopy (J) and secure with the screws (E).

RALPH LAUREN



ASSEMBLY INSTRUCTIONS

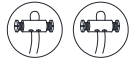

1. Wrap the safety cable into the slot hole on the mounting plate (B).
2. Wrap the safety cable around the cable lock nut.
3. Insert screws into both holes on cable lock nut, secure screws with screwdriver.

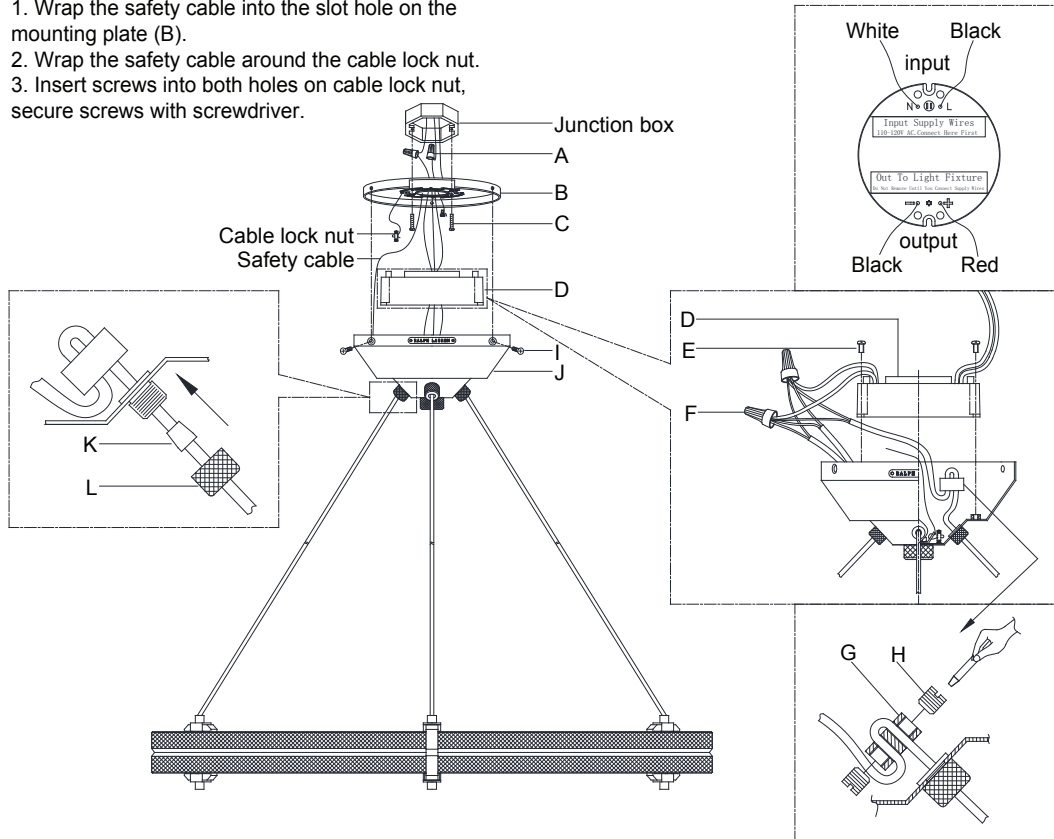

Paxton 24" Ring Chandelier

Item # RL 5670

NOTICE:

This light fixture should be installed in accordance with all applicable, local installation codes, and by a person familiar with the construction and operation of it, as well as the hazards involved. Inspect item and contents carefully. If any damage or defect is found, do not install. Retain all packaging material until installation is complete and approved.

11. Connect the fixture black wires to the driver output black wire using the wire nut (F) and wrap it with the electrical tape (not included).
12. Connect the fixture red wires to the driver output red wire using the wire nut (F) and wrap it with the electrical tape (not included).
PLEASE NOTE: It is recommended to have a helper to assist in supporting the fixture while connecting safety cable and electrical wires.
13. Connect the safety cable as shown in diagram.
14. Connect the driver input white wire to the neutral wire in the junction box using the wire nut (A).
15. Connect the driver input black wire to the hot wire in the junction box using the wire nut (A).
DO NOT REVERSE THE HOT AND NEUTRAL CONNECTIONS OTHERWISE SAFETY WILL BE COMPROMISED.
16. Carefully tuck the wire connections into the junction box.
17. Install the canopy (J) to the mounting plate (B) and secure with the canopy screws (I).
18. To level the fixture unscrew cap nut (L), feed the fixture wire through stopper (K) and then re-secure cap nut (L). Repeat as needed with other wires.
19. Carefully remove the protective film on the fixture body.
20. Installation is complete, turn on power at fuse or circuit breaker.

Care Instructions: Clean only with a soft dry cloth or feather duster. Do not use abrasive or chemical agents.

RALPH LAUREN

