

LANTERN TO BE ASSEMBLED AS SHOWN IN TOP VIEW—MOUNTED ACROSS FLATS.

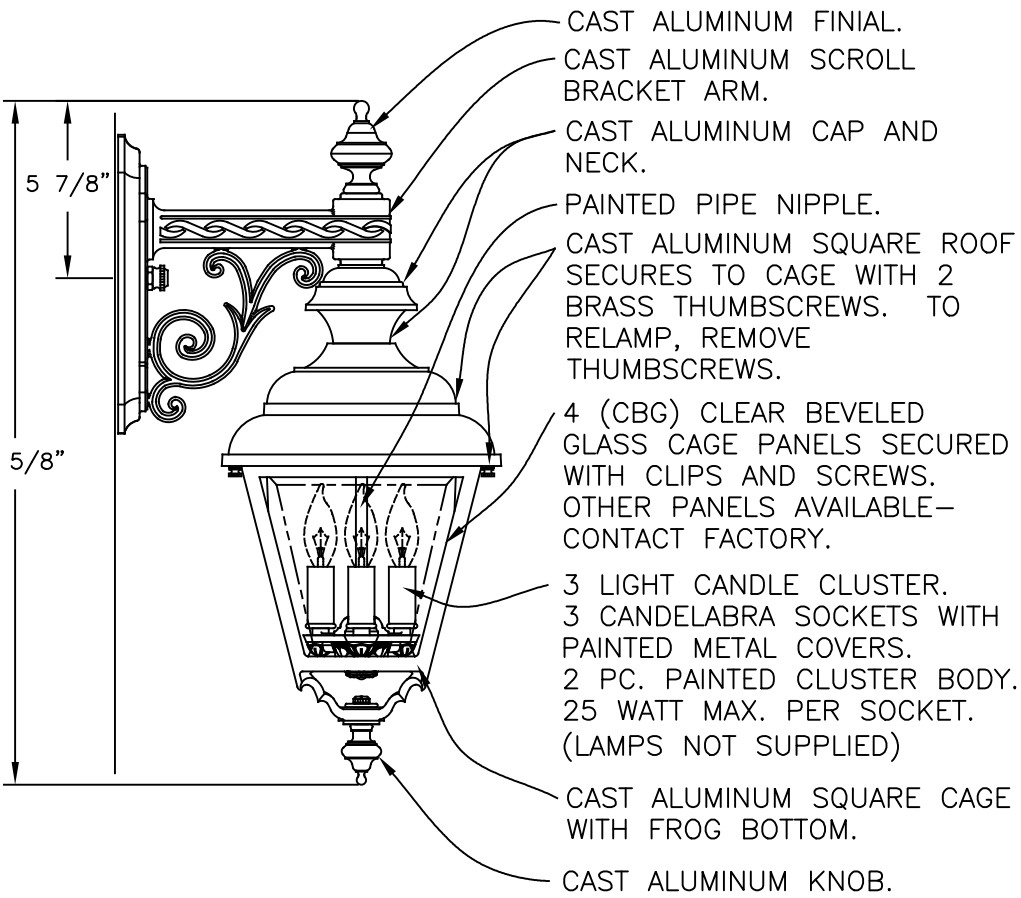
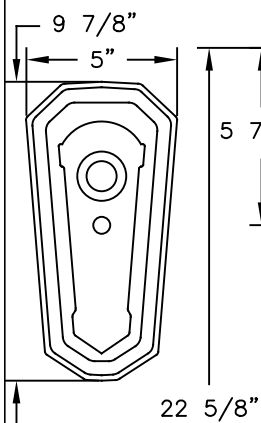

LANTERN IS PREWIRED AND TESTED.
 ALL ELECTRICAL COMPONENTS ARE U.L. LISTED.
 ALL MOUNTING HARDWARE IS SUPPLIED.

HEIGHT	22 5/8"
WIDTH	9 1/4"
PROJECTION	12 3/4"
TOP TO OUTLET	5 7/8"

Drawing for illustration only — scale approximate

	TITLE: PLYMOUTH™ 9500 SERIES WALL BRACKET LANTERN	
	SCALE: 1=4 DATE: 01/30/05	DWG BY: JEK

425 E. MIDDLE ST. HANOVER, PA 17331
 PH: (717) 632-6464 - FAX: (717) 699-2930