

CAST ALUMINUM ROOF SECURES TO TOP CAGE FRAME WITH 2 S.ST'L. SET SCREWS. TO RELAMP, REMOVE SET SCREWS.

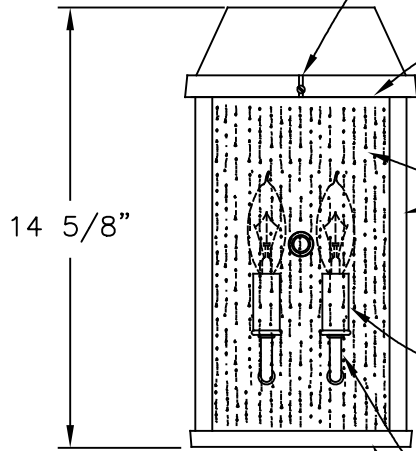

CAST ALUMINUM TOP CAGE FRAME ATTACHES TO LEGS WITH 8-32 S.ST'L. MACHINE SCREWS.

EXTRUDED ALUMINUM CAGE LEGS WITH "U" CHANNELS SECURE 3 CLEAR SEEDED ACRYLIC (CSA) CAGE PANELS. OTHER PANELS AVAILABLE-CONTACT FACTORY.

2 CANDELABRA SOCKETS WITH PAINTED METAL COVERS. 25 WATTS MAX. PER SOCKET. (LAMPS NOT SUPPLIED).

PAINTED ALUMINUM STEMS.

CAST ALUMINUM BOTTOM CAGE FRAME ATTACHES TO LEGS WITH 8-32 S.ST'L. MACHINE SCREWS AND IS OPEN FOR ADDED DOWNLIGHT.

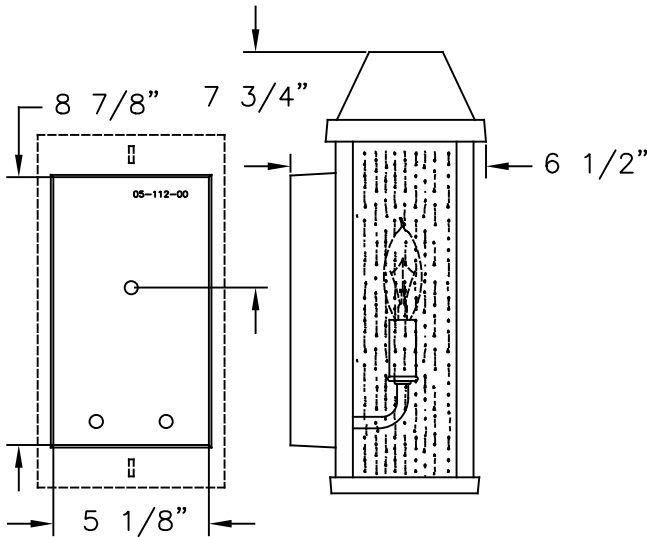

LANTERN WILL BE PREWIRED AND TESTED.
ALL ELECTRICAL COMPONENTS ARE UL. LISTED.
MOUNTING HARDWARE SUPPLIED.

HEIGHT	14 5/8"
WIDTH	7 3/4"
PROJECTION	6 1/2"
TOP TO OUTLET	7 3/4"

Drawing for illustration only - scale approximate

Hanover
LANTERN

425 E. MIDDLE ST. HANOVER, PA 17331
PH: (717) 632-6464 - FAX: (717) 699-2930

SCALE: 1=4 DATE: 02/18/05 DWG BY: JEK

TITLE: "SALEM"
8500 SERIES
WALL BRACKET
LANTERN

DWG. NO. B8503