

- CAST ALUMINUM LOOP.
- CAST ALUMINUM ROOF SECURES TO TOP CAGE FRAME WITH (2) 8-32 BRASS THUMBSCREWS. TO RELAMP, REMOVE THUMBSCREWS.
- CAST ALUMINUM TOP CAGE FRAME ATTACHES TO LEGS WITH 8-32 S.ST'L. MACHINE SCREWS.
- EXTRUDED ALUMINUM CAGE LEGS WITH "U" CHANNELS SECURE 3 CLEAR ACRYLIC (CA) CAGE PANELS. OTHER PANELS AVAILABLE-CONTACT FACTORY.
- BRASS REFLECTOR IS POLISHED AND CLEAR LACQUERED.
- 2 CANDELABRA SOCKETS WITH PAINTED METAL COVERS. 25 WATTS MAX. PER SOCKET. (LAMPS NOT SUPPLIED).
- PAINTED ALUMINUM STEMS.
- CAST ALUMINUM BOTTOM CAGE FRAME ATTACHES TO LEGS WITH 8-32 S.ST'L. MACHINE SCREWS.

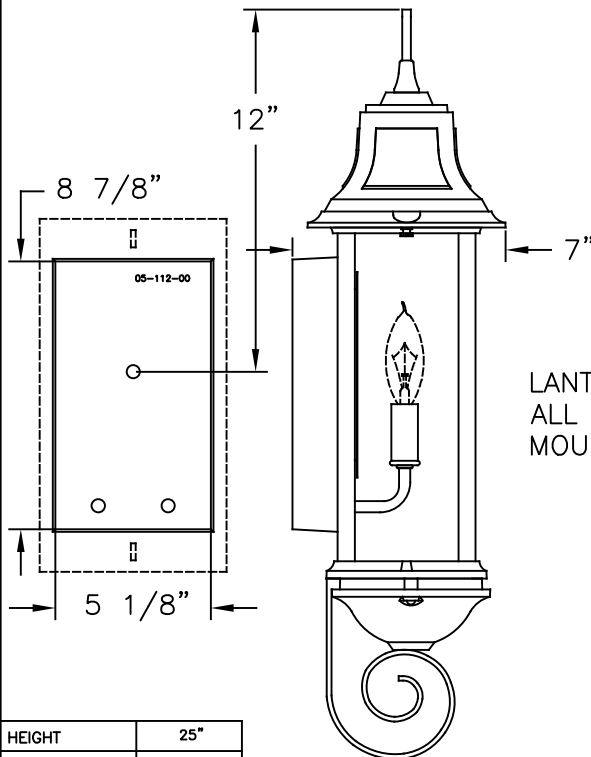

LANTERN WILL BE PREWIRED AND TESTED. ALL ELECTRICAL COMPONENTS ARE UL. LISTED. MOUNTING HARDWARE SUPPLIED.

HEIGHT	25"
WIDTH	9"
PROJECTION	7"
TOP TO OUTLET	12"

Drawing for illustration only - scale approximate

Hanover
LANTERN

425 E. MIDDLE ST. HANOVER, PA 17331
PH: (717) 632-6464 - FAX: (717) 669-2630

SCALE: 1=4 DATE: 02/18/05 DWG BY: JEK

TITLE: "SALEM"
8500 SERIES
WALL BRACKET
LANTERN

DWG. NO. B8502