

LANTERN TO BE ASSEMBLED AS SHOWN IN TOP VIEW— MOUNTED ACROSS FLATS.

17 1/2"

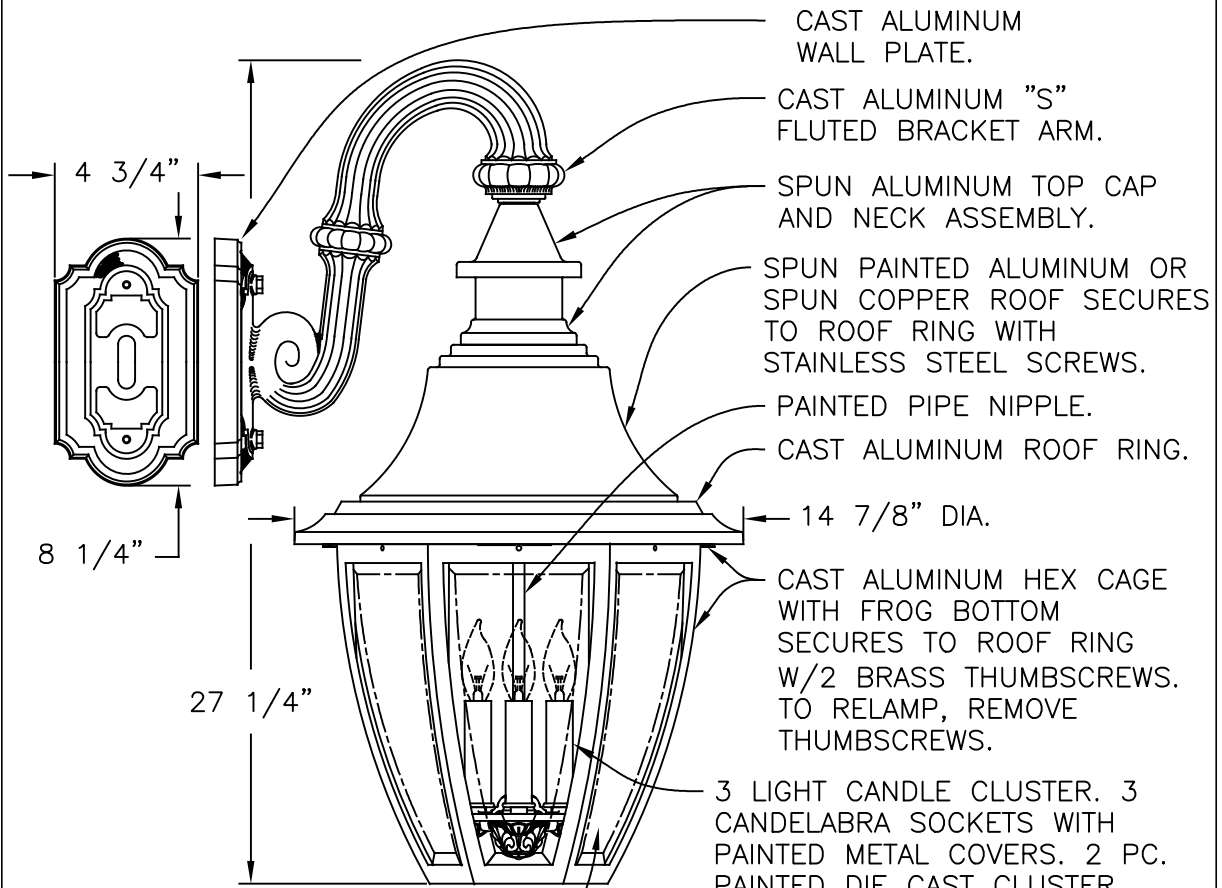

CAST ALUMINUM WALL PLATE.

CAST ALUMINUM "S" FLUTED BRACKET ARM.

SPUN ALUMINUM TOP CAP AND NECK ASSEMBLY.

SPUN PAINTED ALUMINUM OR SPUN COPPER ROOF SECURES TO ROOF RING WITH STAINLESS STEEL SCREWS.

PAINTED PIPE NIPPLE.

CAST ALUMINUM ROOF RING.

14 7/8" DIA.

CAST ALUMINUM HEX CAGE WITH FROG BOTTOM SECURES TO ROOF RING W/2 BRASS THUMBSCREWS. TO RELAMP, REMOVE THUMBSCREWS.

3 LIGHT CANDLE CLUSTER. 3 CANDELABRA SOCKETS WITH PAINTED METAL COVERS. 2 PC. PAINTED DIE CAST CLUSTER BODY. 25 WATTS MAX PER SOCKET. (LAMP NOT SUPPLIED).

6 CLEAR BEVELED GLASS (CBG) CAGE PANELS SECURE TO CAGE WITH CLIPS AND SCREWS. (OTHER PANELS AVAILABLE— CONTACT FACTORY)

LANTERN WILL BE PREWIRED AND TESTED.
ALL ELECTRICAL COMPONENTS ARE U.L. LISTED.
ALL MOUNTING HARDWARE IS SUPPLIED.

HEIGHT	27 1/4"
WIDTH	14 7/8" DIA.
PROJECTION	17 1/2"
TOP TO OUTLET	10"

Drawing for illustration only — scale approximate

Hanover
LANTERN

425 E. MIDDLE ST. HANOVER, PA 17331
PH: (717) 632-6464 - FAX: (717) 699-2630

SCALE: 1=4 DATE: 12/13/04 DWG BY: ATV

TITLE:
"SUFFOLK"
52600 SERIES
BRACKET LANTERN

DWG. NO.
B526FRM