

LANTERN TO BE ASSEMBLED AS SHOWN IN TOP VIEW—MOUNTED ACROSS FLATS.

16"

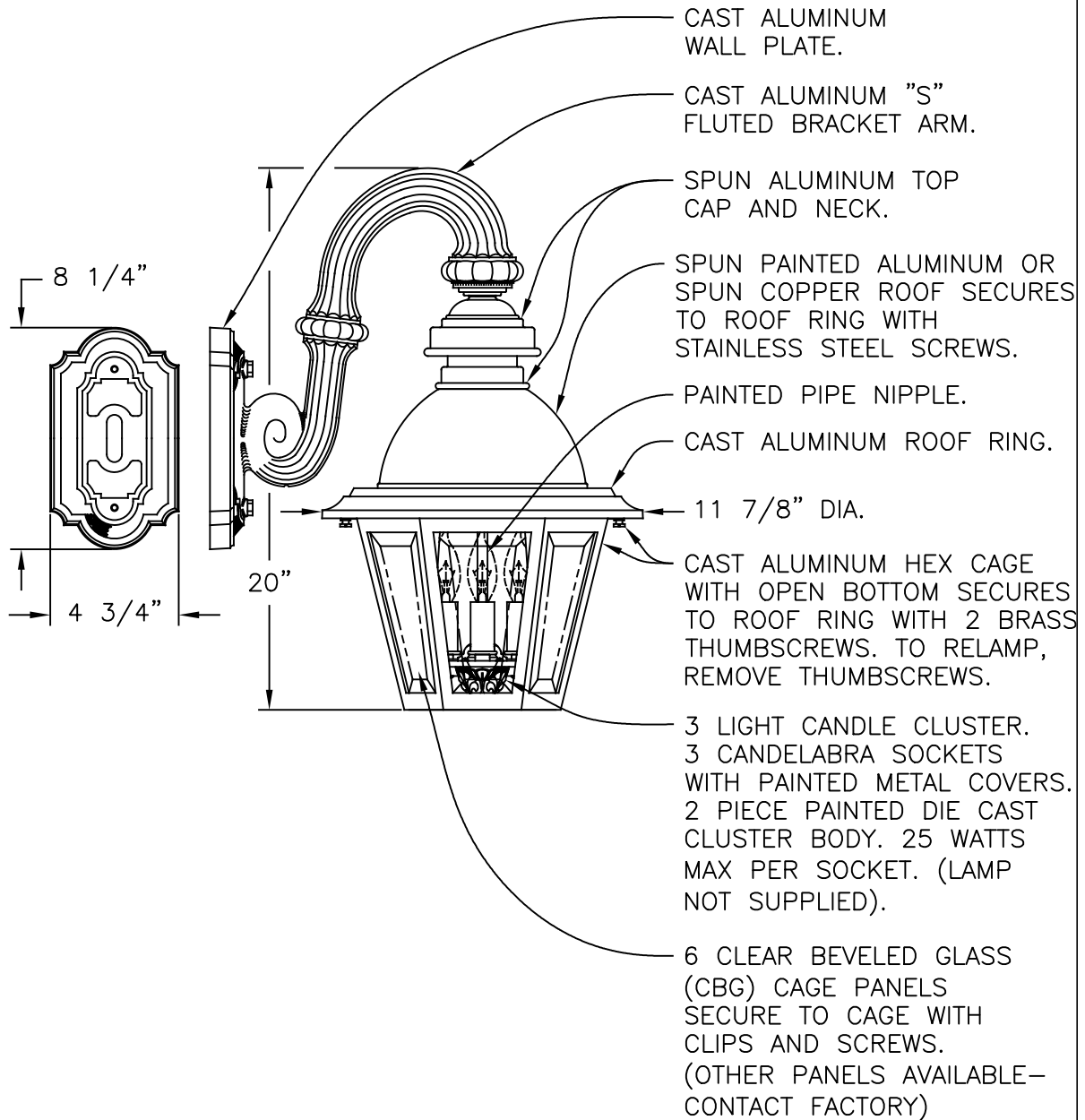

CAST ALUMINUM WALL PLATE.

CAST ALUMINUM "S" FLUTED BRACKET ARM.

SPUN ALUMINUM TOP CAP AND NECK.

SPUN PAINTED ALUMINUM OR SPUN COPPER ROOF SECURES TO ROOF RING WITH STAINLESS STEEL SCREWS.

PAINTED PIPE NIPPLE.

CAST ALUMINUM ROOF RING.

11 7/8" DIA.

CAST ALUMINUM HEX CAGE WITH OPEN BOTTOM SECURES TO ROOF RING WITH 2 BRASS THUMBSCREWS. TO RELAMP, REMOVE THUMBSCREWS.

3 LIGHT CANDLE CLUSTER. 3 CANDELABRA SOCKETS WITH PAINTED METAL COVERS. 2 PIECE PAINTED DIE CAST CLUSTER BODY. 25 WATTS MAX PER SOCKET. (LAMP NOT SUPPLIED).

6 CLEAR BEVELED GLASS (CBG) CAGE PANELS SECURE TO CAGE WITH CLIPS AND SCREWS. (OTHER PANELS AVAILABLE—CONTACT FACTORY)

LANTERN WILL BE PREWIRED AND TESTED. ALL ELECTRICAL COMPONENTS ARE U.L. LISTED. ALL MOUNTING HARDWARE IS SUPPLIED.

HEIGHT	20"
WIDTH	11 7/8" DIA.
PROJECTION	16"
TOP TO OUTLET	10"

Drawing for illustration only — scale approximate

**Hanover**  
LANTERN

425 E. MIDDLE ST. HANOVER, PA 17331  
PH: (717) 632-6464 - FAX: (717) 699-2930

SCALE: 1=4    DATE: 12/13/04    DWG BY: ATV

TITLE:  
"SOUTH BEND"  
51400 SERIES  
BRACKET LANTERN

DWG. NO.  
B514FRM