

LANTERN TO BE ASSEMBLED AS SHOWN IN TOP VIEW— MOUNTED ACROSS FLATS.

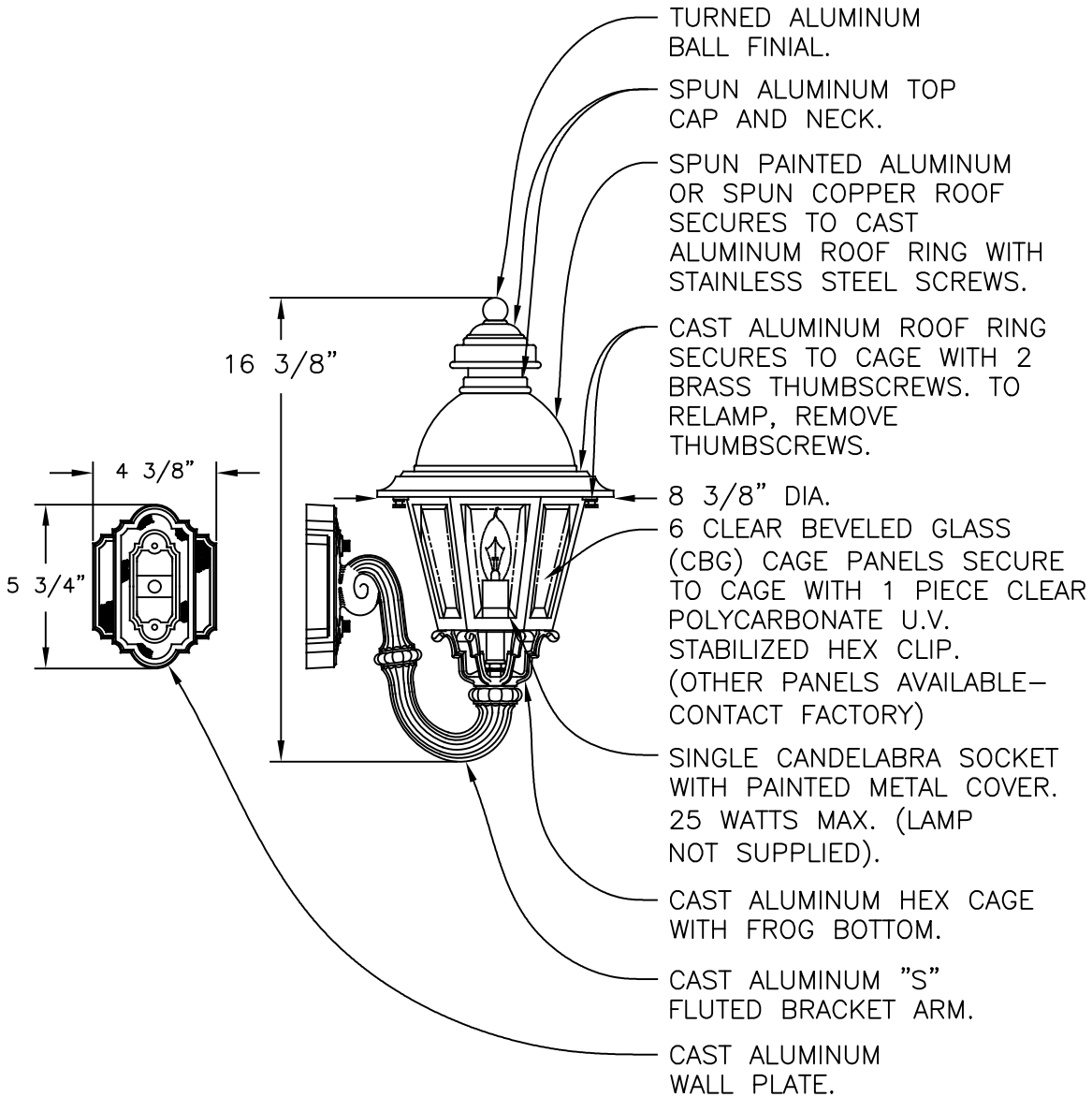

- TURNED ALUMINUM BALL FINIAL.
- SPUN ALUMINUM TOP CAP AND NECK.
- SPUN PAINTED ALUMINUM OR SPUN COPPER ROOF SECURES TO CAST ALUMINUM ROOF RING WITH STAINLESS STEEL SCREWS.
- CAST ALUMINUM ROOF RING SECURES TO CAGE WITH 2 BRASS THUMBSCREWS. TO RELAMP, REMOVE THUMBSCREWS.
- 8 3/8" DIA.
- 6 CLEAR BEVELED GLASS (CBG) CAGE PANELS SECURE TO CAGE WITH 1 PIECE CLEAR POLYCARBONATE U.V. STABILIZED HEX CLIP. (OTHER PANELS AVAILABLE— CONTACT FACTORY)
- SINGLE CANDELABRA SOCKET WITH PAINTED METAL COVER. 25 WATTS MAX. (LAMP NOT SUPPLIED).
- CAST ALUMINUM HEX CAGE WITH FROG BOTTOM.
- CAST ALUMINUM "S" FLUTED BRACKET ARM.
- CAST ALUMINUM WALL PLATE.

LANTERN WILL BE PREWIRED AND TESTED.
 ALL ELECTRICAL COMPONENTS ARE U.L. LISTED.
 ALL MOUNTING HARDWARE IS SUPPLIED.

HEIGHT	16 3/8"
WIDTH	8 3/8" DIA.
PROJECTION	10 7/8"
TOP TO OUTLET	10 1/4"

Drawing for illustration only — scale approximate

	TITLE: "SOUTH BEND" 51200 SERIES BRACKET LANTERN		
	425 E. MIDDLE ST. HANOVER, PA 17331 PH: (717) 632-6464 - FAX: (717) 699-2930	SCALE: 1=4	DATE: 06/06/02
	DWG BY: ATV		