

Collection: GEM

Product #: CHB0039-12

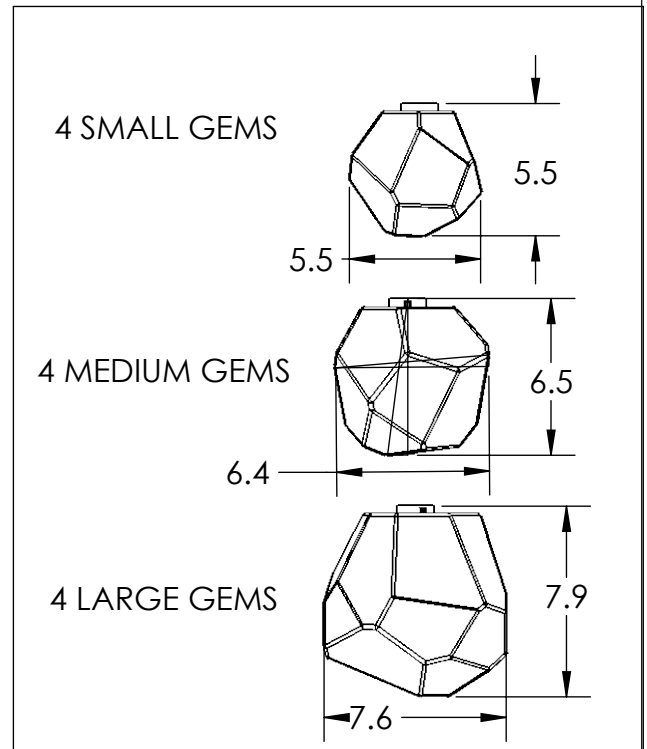
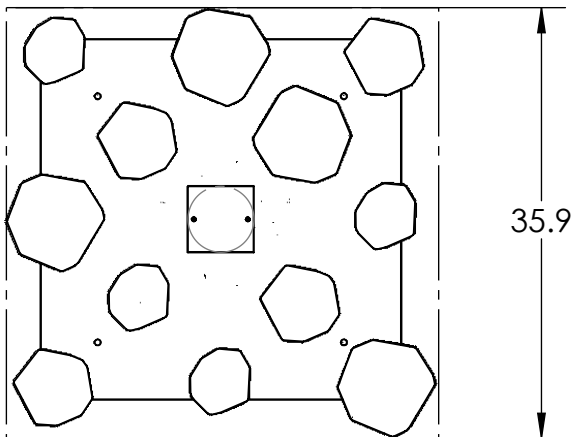
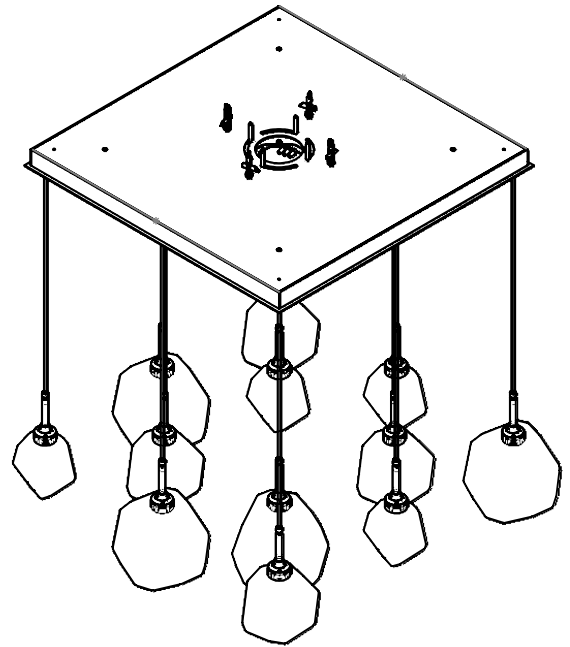
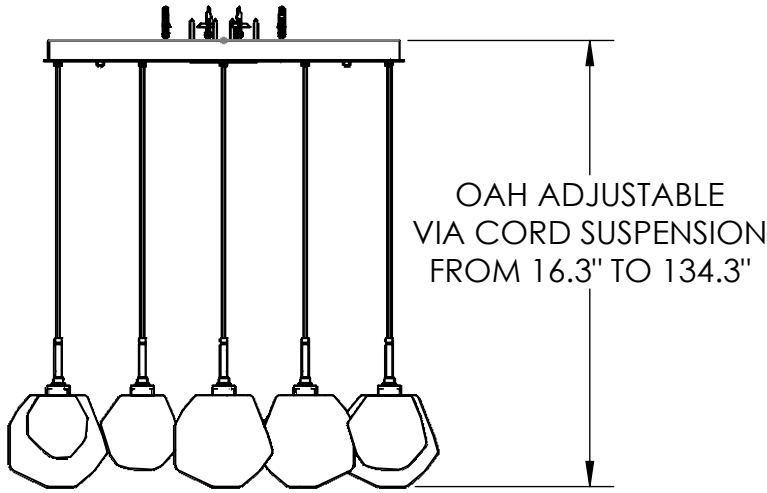

Visit hammertonstudio.com for product options and specifications.

12/7/2022 ©

Mounting Packet: R	Weight(lbs.): 85	Electrical Type: LED	CCT: 2700/3000 K
UL Location: DRY		Elec. Qty: 12	Wattage: 62
Finish: SEE WEB SITE FOR OPTIONS		Source Lumens: Up: N/A	Down: 4105
Top Diffuser: CLOSED		Dimmable: Forward/Reverse Phase To 1%	
Bottom Diffuser: CLOSED GLASS		CRI: 90+	Power Factor: >0.9

All fixtures created by Hammerton are handcrafted by artisans. Dimensions may vary up to 7/8".

© Copyright 2021. All rights in design, detail or invention of this drawing are reserved as the property of Hammerton. Any imitation or adaptation without written consent is strictly prohibited.

Mounting Detail

